

STEPS TO SET UP YOUR FLOW SET TOP BOX

This easy step-by-step guide takes the guess work out of installation and gets you on your way to a world of entertainment in no time.



WHAT ELSE YOU'LL FIND IN THIS BOX



Remote Control



HDMI Cable



RCA/AV Cable



Power Cable



Ethernet Cable

HOW TO INSTALL THE SET TOP BOX

STEP 1

Connect one of end of the ethernet cable provided to the available ethernet IPTV port at the back of your Optical Network Terminal (ONT). (Port 2,3 or 4 only)

Connect the other end of the ethernet cable to the ethernet port at the back of the Set Top Box.

STEP 2

HDMI Input: Connect the HDMI cable provided to the available HDMI port on your television. Connect the other end of the HDMI cable to the HDMI port at the back of the FLOW Set Top Box.

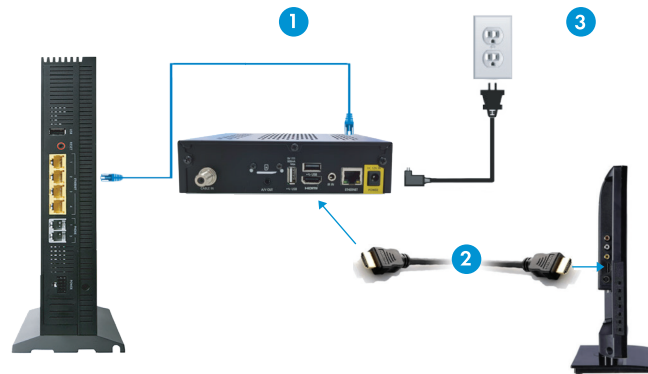

OR

RCA/AV input: Connect the RCA/AV cable provided to the RCA/AV ports on your television. Connect the other end of the RCA/AV cable to the A/V Out port at the back of the FLOW Set Top Box

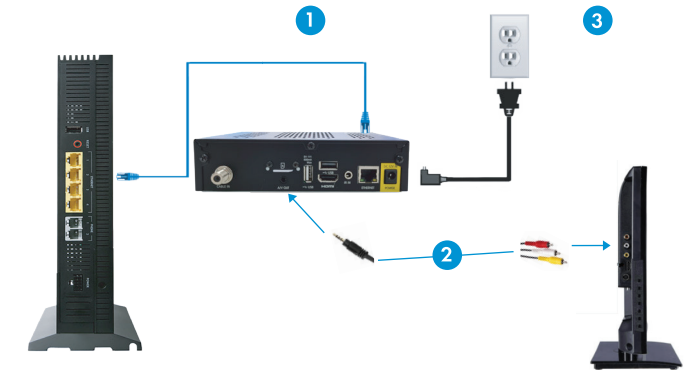

STEP 3

Connect the power cable to the power cable port at the back of the FLOW Set Top Box. Connect the other end of the power cable to the electrical power source.

STEP 4

Ensure your television is on the corresponding source input the FLOW Set Top Box is connected to on your television.



GET TO KNOW YOUR EQUIPMENT

836 ONT

Ethernet ports 1 – 4

Ethernet port 1 is provisioned for the delivery of the internet service while Ethernet ports 2-4 are provisioned for the delivery of the IPTV service.



844 ONT

Ethernet ports 1 – 4

Ethernet port 1 is provisioned for the delivery of the internet service while Ethernet ports 2-4 are provisioned for the delivery of the IPTV service.

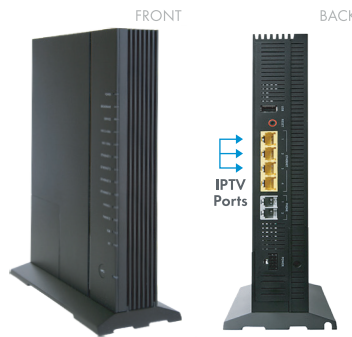

SET TOP BOX

- a. Power Indicator
- b. SIM card
- c. CABLE IN (Coaxial)
- d. A/V OUT
- e. USB port
- f. HDMI port
- g. IR input
- h. ETHERNET port
- i. Power cable connector
- j. USB port

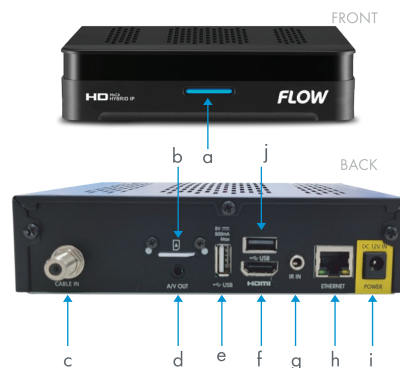

TROUBLESHOOTING

1. The FLOW Set Top Box has no power

Ensure the power cable is connected securely to the Set Top Box and to the power source.

2. The FLOW Set Top Box LED stays red

Press the power button on the FLOW Remote or unplug and reconnect the power cable.

3. My television says "No signal"

Ensure the HDMI or RCA/AV cable is connected securely to the Set Top Box and to your television.

Ensure your television is on the correct source input.

4. My television says "Connection Problem, Please ensure all cables are connected"

Ensure the Ethernet cable is connected securely to lan 2, 3 or 4 on the ONT and to the Set Top Box. If the problem persists, please contact Customer Care at **1-800-804-2994**.

5. Channels are not loading

Reboot the Set Top Box by unplugging and reconnecting the power cable. If the problem persists, please contact Customer Care at **1-800-804-2994**.

6. My Television says "DRM License error"

Try navigating to channel 127 using the FLOW remote or select any channel from the EPG/Guide menu OR you can reboot the Set Top Box by unplugging and reconnecting the power cable. If the problem persists, please contact customer care at **1-800-804-2994**.

discoverflow.co/barbados/tvselfinstall

fold

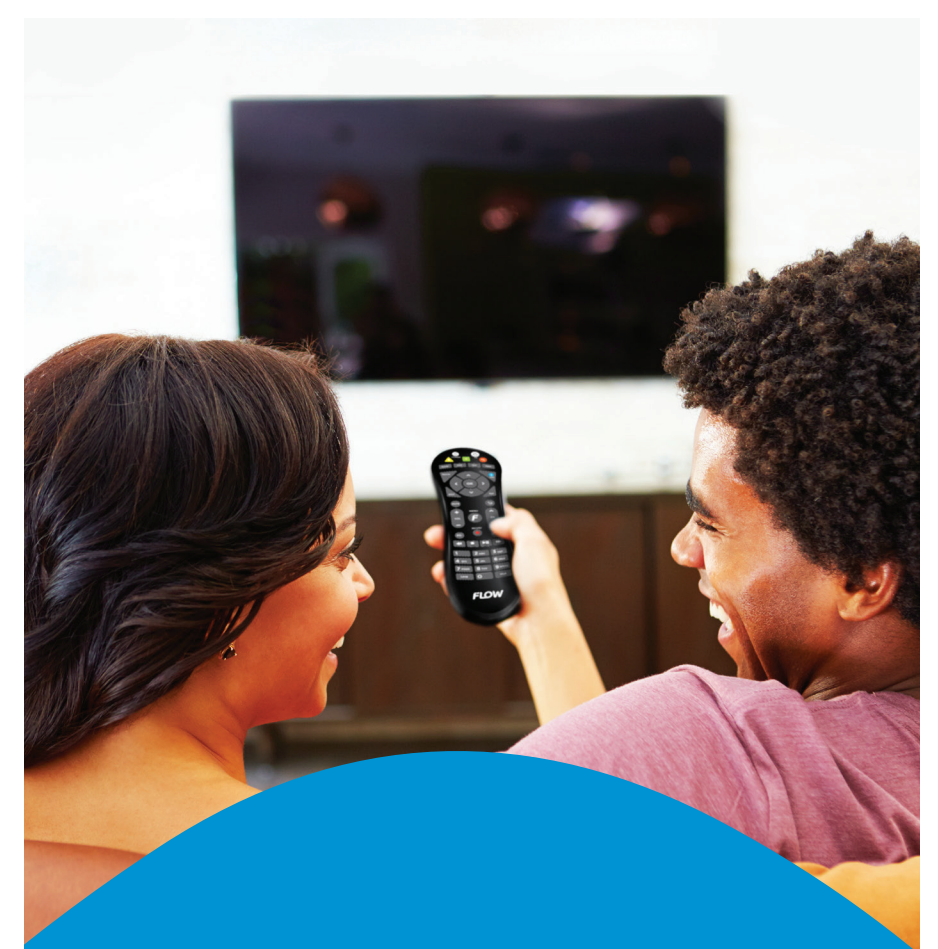

FLOW

QUICK CONNECT GUIDE

fold